

Technical data | TES heavy-load series

By combining the most advanced precision manufacturing as well as using premium materials, we have created an extremely durable and easy-to-maintain gearbox. The modular gearbox design enables the individual planetary stages to be supported individually. This also strongly reduces the operation-related wear and significantly increases the service life of the gearbox

- Available from 200 to 12,000 Nm
- Freely rotatable gearbox
- Fast and precise
- 2-speed gear box right/left
- 200 torque settings
- Stored module construction for continuous use
- Are fitted with a torque cutoff system, giving an accuracy of +/- 3.5% under unchanging conditions
- Are fast, precise and safe and make little noise
- Are available in 230 volt and 110 volt versions
- Newly designed drive motor characterized by its robust and easy-to-maintain design as well as its high power reserves.
- Has clockwise and counterclockwise rotation as well as a 2-speed gearbox and can be adjusted to 200 different torque ranges
- Free positioning of the control unit; the drive motor can rotate freely around 360° - this allows the device to be comfortably positioned on the screw connection
- Can be optionally equipped with a load activation. This allows the twist occurring between the slip nut and support to be independently released. During this process, the drive motor turns in the reverse direction for a short time. This option is essential for short installation times and offers an ultimate degree of safety.

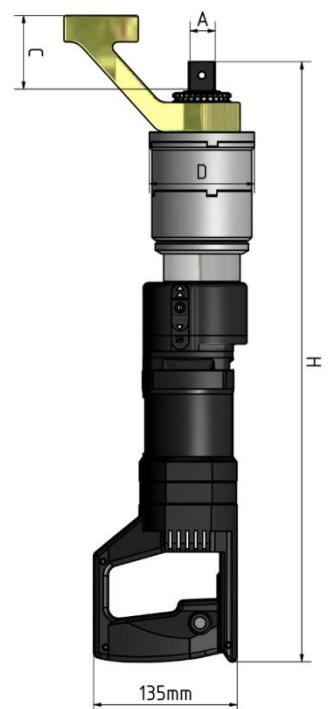

TYP / TYPE		TES - 245	TES - 355	TES - 505	TES - 605	TES - 905	TES - 1205	
Modulare Getriebeeinheit modular gearbox		TESL - 245	TESL - 355	TESL - 505	TESL - 605	TESL - 905	TESL - 1205	
Art.-Nr. TES -		50 245 120	50 355 130	50 505 140	50 605 150	50 905 160	50 915 170	
Art.-Nr. TESL -		50 245 320	50 355 330	50 505 340	50 605 350	50 905 360	50 915 370	
Leistung / Torque		Nm						
		360 - 2.500	360 - 3.500	700 - 5.000	816 - 6.000	1.024 - 10.000	1.400 - 12.000	
Antriebsvierkant / Square drive	A	Zoll inch	1"	1 1/2"	1 1/2"	1 1/2"	1 1/2"	
Höhe (mm) / Height	C	mm	75	95	95	110	110	115
Getriebe Ø / Gear diam.	D	mm	99	99	99	135	135	172
Höhe / Height	H	mm	570	580	630	615	660	660
Reaktionsarm / torque support		kg	1,6	3,5	3,5	5,7	5,7	5,7
Gewicht* / Weight		kg	10,6	11,5	13,7	16,9	20,5	29
Leerlaufdrehzahl ** / Idle speed		U/m r/m	10	9	3	6,5	2,5	2

* ohne Reaktionsarm / without torque support

** 2. Gang / 2. speed gear

Technische Änderungen vorbehalten / Subject to technical changes